

# EVERHARD SPEC PACK



PRODUCT INFO | IMAGES | DRAWINGS

## PRODUCT

EI Trade 1080 LH 1.75 Bowl & Drainer

## EI CODE

73193

## BRAND

EI Trade



# SPEC PACK EI TRADE COLLECTION

SPEC SHEET



## EI TRADE 1080 LH 1.75 BOWL & DRAINER

### PRODUCT CODE:

73193

### FEATURES:

- / 18.5L and 11L bowl with one tap hole
  - / 304 stainless steel bowl
  - / 90mm stainless steel basket waste
- Also available in RH



### OVERALL DIMENSIONS:

1080 L x 480 W x 170mm D

### WEIGHT:

7.6kg

### WARRANTY:

10 years

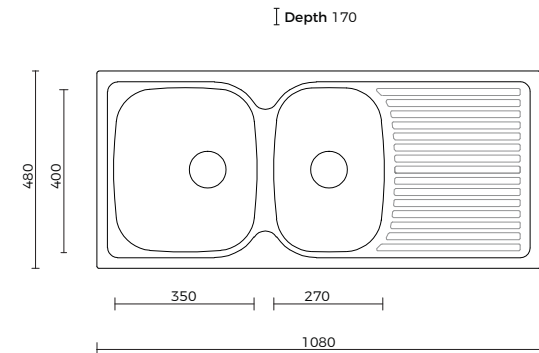

Disclaimer: All measurement are in millimetres and are solely for reference purposes. Colours have been reproduced with as much accuracy as possible. Any changes resulting from technical advance of design or colour may be made without prior notice. Tapware, accessories and appliances are for illustration purposes only. Further information on warranties is available at [www.everhard.com.au](http://www.everhard.com.au)

# SPEC PACK EI TRADE COLLECTION

## PRODUCT DRAWING

