

Product Name:
45L Domestic Grease Trap

EI Code:
84010

Dimensions:
638 H x 468 diameter

Weight:
5kg approx

Material:
PP



Additional Information:

Key features of the Everhard 45L Domestic Grease Trap are:

- / Removal Basket

Product Code	Description	Weight Kg
TBA	45L Riser kit with concrete lid	52.5kg

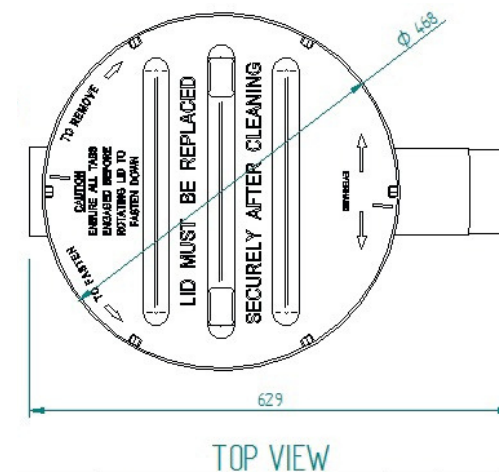
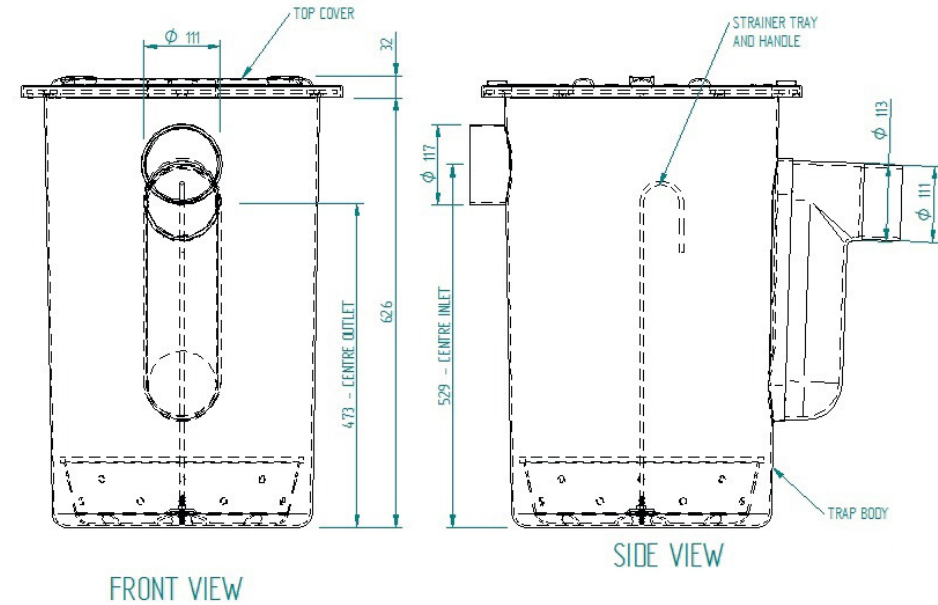

Disclaimer: All measurements are in millimetres and are subject to change without any prior notice. It is advised for this product to be installed by a professional contractor to ensure installation is correct. Further information is available at www.everhard.com.au